

User Manual

PENTA

5-Channel Power Amp

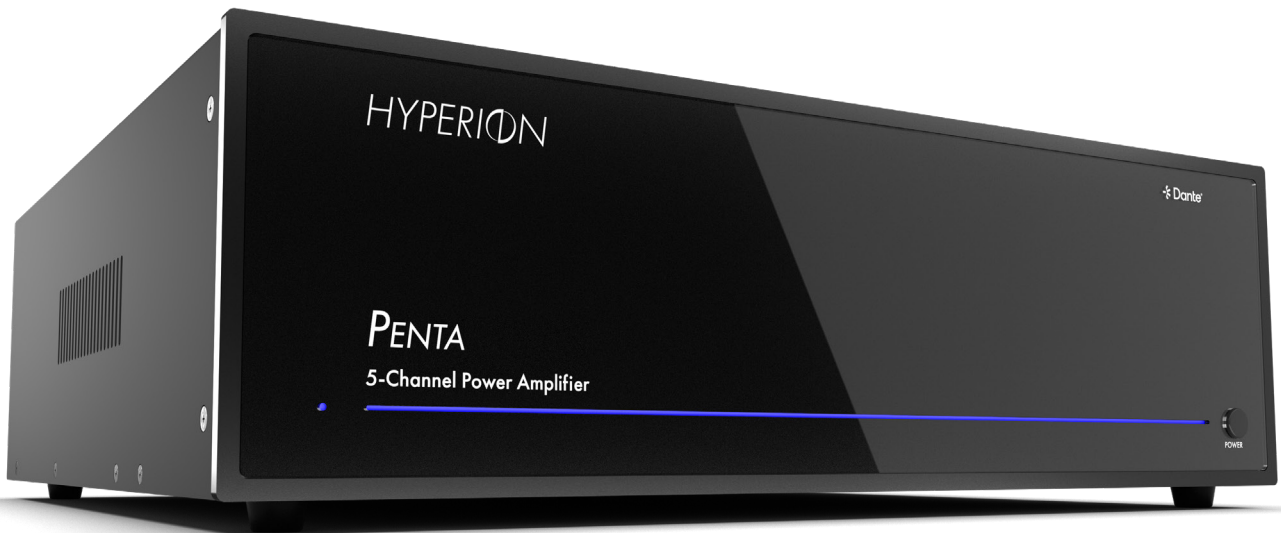

Table of Contents

Table of Contents	You Are Here
Important Safety Instructions.....	3
Introduction.....	4
Features	4
What's In the Box.....	4
Specifications.....	5
Compatible Products	6
Front Panel Overview.....	7
Rear Panel Overview.....	8
Quick Start Guide.....	10
Speaker Wiring	11
Installation	12
Speaker Configurations.....	13
+12V Trigger In/Out	15
Using Dante Controller	16
Troubleshooting.....	17
Support.....	18
Warranty	19

Important Safety Instructions

1. Read these instructions.
2. Keep these instructions.
3. Heed all warnings.
4. Follow all instructions.
5. Do not use this apparatus near water.
6. Clean only with a dry cloth.
7. Do not block any ventilation openings. Install in accordance with the manufacturer's instructions.
8. Do not install near any heat sources such as radiators, heat registers, stoves, or other apparatus (including amplifiers) that produce heat.
9. Protect the power cord from being walked on or pinched particularly at plugs, convenience receptacles, and the point where they exit from the apparatus.
10. Only use attachments/accessories specified by the manufacturer.
11. Unplug this apparatus during lightning storms or when unused for long periods of time.
12. Refer all servicing to qualified service personnel. Servicing is required when the apparatus has been damaged in any way, such as power-supply cord or plug is damaged, liquid has been spilled or objects have fallen into the apparatus, the apparatus has been exposed to rain or moisture, does not operate normally, or has been dropped.
13. This apparatus shall not be exposed to dripping or splashing, and no object filled with liquids, such as vases or glasses, shall be placed on the apparatus.



This equipment generates, uses, and can radiate radio frequency energy and, if not installed and used in accordance with the instructions, may cause harmful interference to radio communications. However, there is no guarantee that interference will not occur in a particular installation.

If this equipment does cause harmful interference to radio or television reception, which can be determined by turning the equipment off and on, the user is encouraged to try to correct the interference by one or more of the following measures:

- Reorient or relocate the receiving antenna.
- Increase the separation between the equipment and the receiver.
- Connect the equipment into an outlet on a circuit different from that to which the receiver is connected.
- Consult the dealer or an experienced radio/TV technician for help.

CAUTION: Changes or modifications to this device not expressly approved by AudioControl Inc. could void the user's authority to operate the equipment under FCC rules.

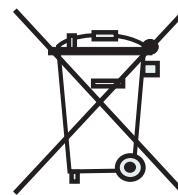

Recycling notice:

If the time comes and this apparatus has fulfilled its destiny, do not throw it out into the trash. It has to be carefully recycled for the good of mankind, by a facility specially equipped for the safe recycling of electronic apparatus. Please contact your local or state recycling leaders for assistance in locating a suitable nearby recycling facility. Or, contact us and we might be able to repair it for you.

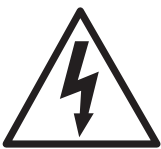

The lightning flash with arrowhead symbol within an equilateral triangle is intended to alert the user to the presence of uninsulated "dangerous voltage" within the product's enclosure, that may be of sufficient magnitude to constitute a risk of electric shock to persons.



The exclamation point within an equilateral triangle is intended to alert the user of the presence of important operating and maintenance (servicing) instructions in the literature accompanying the appliance.

Caution: to reduce the risk of electric shock, do not remove the top cover. There are no user-serviceable parts inside. Refer servicing to qualified personnel. This equipment has been tested and found to comply with the limits for a Class B digital device, pursuant to part 15 of the FCC Rules. These limits are designed to provide reasonable protection against harmful interference in a residential installation.

Introduction

Greetings from the rainforests of the Pacific Northwest, home of AudioControl. Since you are reading this manual, it is safe to say you are in the process of installing a high-performance Hyperion Penta 5-channel theater amplifier. The Penta is a ridiculously powerful and adaptable amplifier which no doubt caught your refined eye. You are obviously a person of fine discernment, have nice hair, and people like the cut of your jib.

The addition of Dante to our amplifier takes the already jaw-dropping performance of classic AudioControl amplifiers, and adds the flexibility of being able to receive audio over IP from anywhere in the system.

The Class H design of the Penta solves a problem most other amplifiers face, where 90% of their power is wasted as heat. The Penta is built to automatically and intelligently adjust the power supply to fit the power demands of the moment, resulting in much cooler operation without the need for bulky heatsinks or fans.

Our high performance components allow enthusiasts to truly enjoy their audio systems. It should provide your customers with years of enjoyment and trouble-free service. We truly feel that this amplifier will enhance the performance of any system.

Features

- Mono/summed stereo pair operations.
- Bridgeable speaker channels, allowing you to output up to 600W.
- Configurable for 5 speakers, or a 3.1 audio system.
- Cool running Class-H design.
- Dante port able to receive audio over IP from any Dante or AES67 transmitting device.
- Balanced XLR and unbalanced RCA inputs.
- Analog RCA loop-through outputs.
- 5-way binding posts.
- Heavy – use for weight lifting when not listening.

What's in the box

- The Penta power amp
- Power cable
- Rack ears



Specifications

Inputs

Analog Inputs	5 Unbalanced RCA and 5 Balanced XLR
Analog Input Impedance	100 kOhm
Analog Input Sensitivity	1.42 Vrms
Maximum Input Voltage	2.7 Vrms
Dante Inputs	1 RJ45 - 5 Channels of Dante Audio

Outputs

Speaker Level Outputs	5 speaker binding posts
Output Power	
Per Channel	230 W @ 8 Ohms 300 W @ 4 Ohms
Bridged Mono	600 W @ 8 Ohms
Minimum Speaker Load	4 Ohms (8 Ohms bridged)

Performance

Frequency Range	10 Hz - 20 kHz \pm 1dB
Total Harmonic Distortion	0.04% (230 watts @ 8 ohms 20 Hz-20 kHz)
Damping Factor	> 450
Signal to Noise Ratio	> 102 dB (A-wtd ref, Full Output)

Dimensions

Dimensions (WxDxH)	17" x 16.5" x 5.25" 43.2 cm x 41.9 cm x 13.3 cm
Width (Rack Ears On)	19" (48.26 cm)
Weight	43 lbs. (19.5 kg)
Rack Space	3U
Coffee of the Day	Wild Leaves Fall Blend

Compatible Products

APR-16

ACP-HYPE-APR-16

- State-of-the-art immersive processing for unrivaled sonic precision.
- Professional HDMI™ switching with full EDID & HDCP management



Axis10

ACP-AXIS10

- Multi-channel eARC Dante encoder that receives audio directly from your TV and distributes it over a Dante network.
- Encodes up to 8 channels of Dolby Atmos or DTS while simultaneously providing a stereo downmix output.

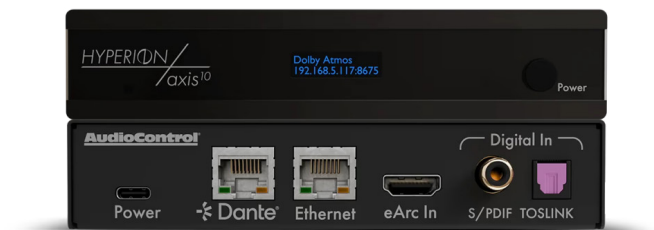

Tetra

ACP-HYPE-TETRA-4

- Dante-enabled for seamless network integration.
- Flexible connectivity connects via balanced, single-ended, or digital audio via Dante



Front Panel Overview

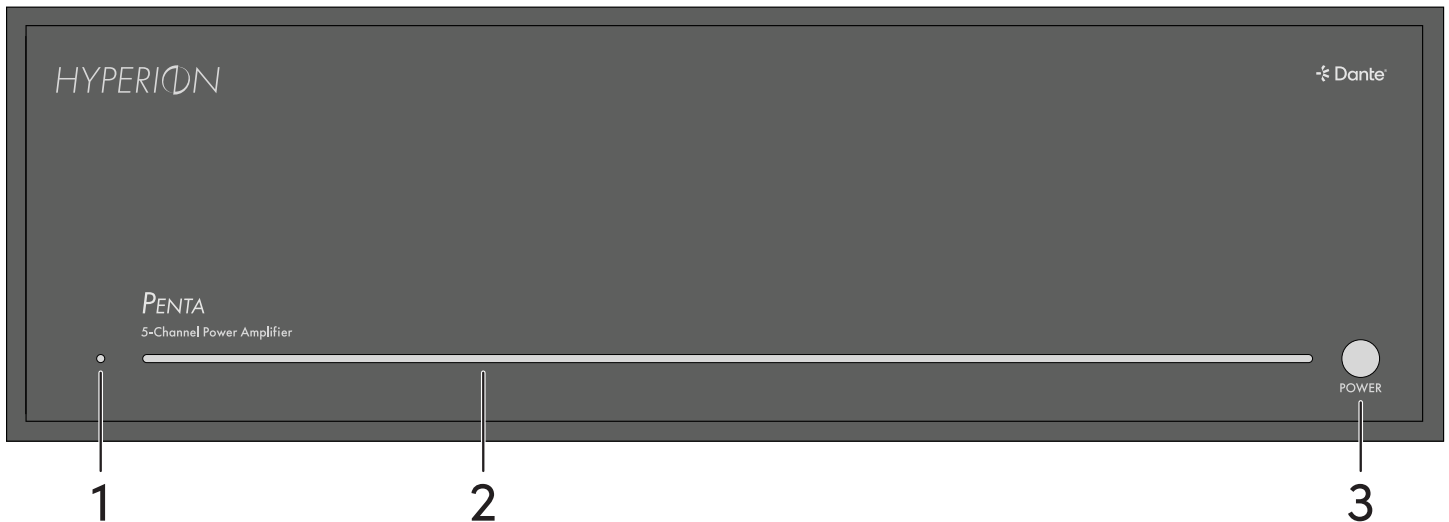

1. **Power LED** - Illuminates to show the current status of the Penta.
 - Solid Blue - The Penta is ON
 - Blinking Blue - The Penta is booting. This process takes about 20 seconds
 - Solid Red - The Penta is in Standby
 - Off - The Penta is either unplugged from wall power, the rear panel Main Power switch is off, or all the lights are out in your town again.
2. **LED Light Bar** - Illuminates blue when the Penta is on. The light bar's brightness can be adjusted via a button on the back panel.
3. **Power Button** - Press this to turn the Penta on or put it into standby.

*This space intentionally left blank for a rousing game of tic-tac-toe.**

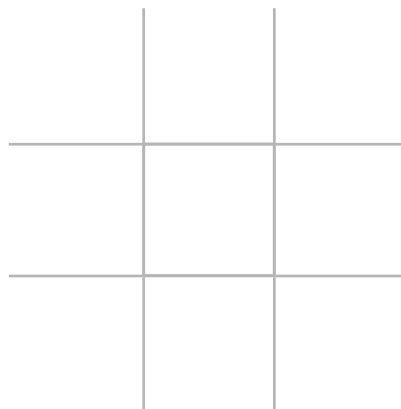

**Noughts & crosses, for our friends across the pond.*

Rear Panel Overview

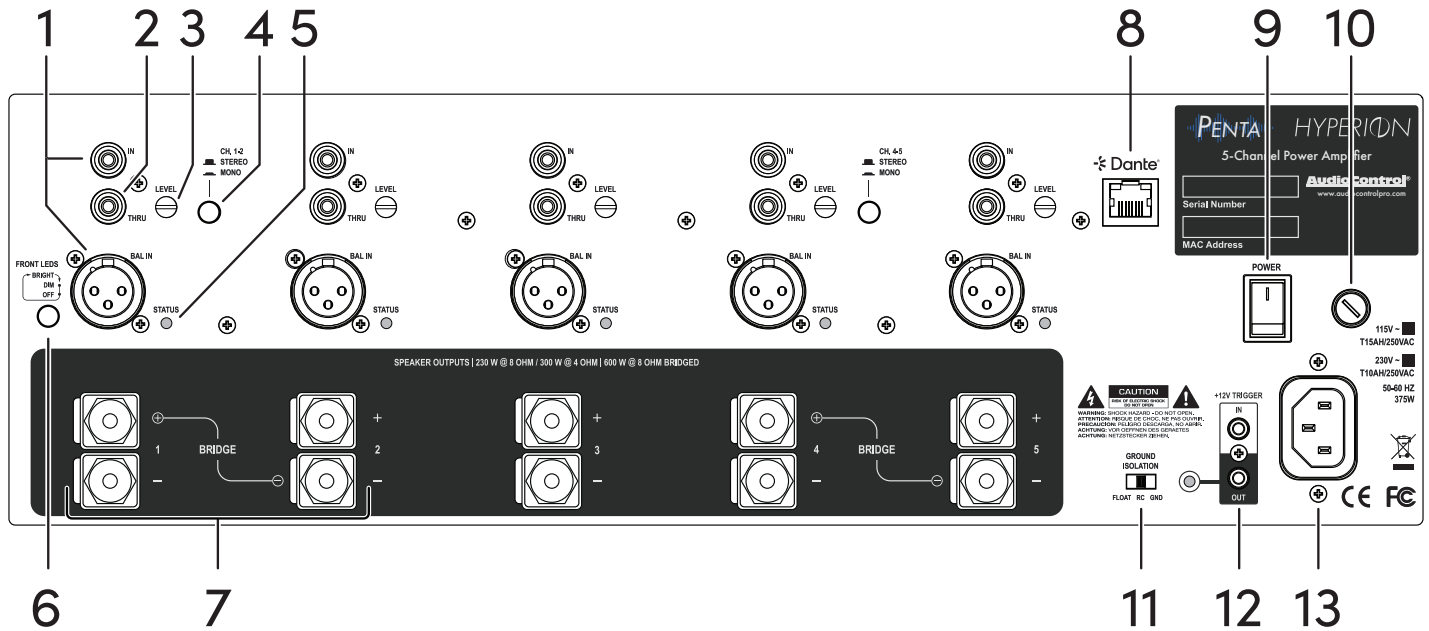

1. **Analog Inputs** - Use either the balanced XLR or unbalanced RCA input. Any line level audio signal can be connected here. The STATUS LED will light blue when the channel is operating normally.
2. **RCA Thru** - These RCA outputs loop the analog audio input signal to another device or section of the Penta. These line-level outputs are hard-wired copies of whatever is coming in on the input.
*These do not copy audio from Dante.
3. **Level** - Gain adjustment for the input signal. When horizontal, the channel is set to 0dB. Rotate clockwise to increase gain, or counterclockwise to decrease gain.
4. **Stereo / Mono** - Set whether the channel pair is in Stereo (each channel is independent), or Mono (the 2 channels are summed together). When bridging, set the pair to Mono. When set to Mono, only 1 input signal is needed to create an output.
5. **Status LED** - Shows the status of the channel.
Blue - The channel is on and functioning normally.
Red - An issue has been detected.
Off - The channel is off.
Taupe - Dinner is served.
6. **Light Bar Brilliance Setting** - Toggle this button to set the desired luminescence of the front panel LEDs to Bright, Dim, or Off.

7. **Speaker Outputs** - High-current terminal blocks, designed to accept large gauge audiophile speaker wiring, and standard 0.75" spaced banana plugs.
8. **Dante Port** - Connect a Cat5e (or better) cable from this port to a local network for the Penta to receive audio from other Dante enabled devices.
9. **Power Switch** - Shuts off the main AC power. Turn the Penta off if the system is going to be unused for an extended period of time. Use the front panel button or trigger inputs to switch the unit between Standby and On.
10. **AC Fuse** - Main power supply fuse may be checked or replaced. Make sure the power cord is unplugged from the Penta before checking or replacing the fuse.
11. **Ground Isolation Switch** - Select the level of isolation between the audio signal ground and the AC earth ground. Typically, this should be left set to GND. If there is an issue with an AC ground hum, try the other settings.
12. **Master Trigger In/Out** - TS 1/8" connectors for triggering this unit and/or other units. Connect a trigger from a device like a preamp to the trigger IN. When 5-12V is received the Penta will turn on, and when the voltage goes away the Penta will turn off. When on, the trigger OUT will provide +12V to power on other devices in the system, and will drop to 0V when the Penta is off.
13. **AC Input** - Connect the supplied AC power cord securely to this input, and plug the other end into an AC mains outlet matching the correct voltage for your unit (marked on the right edge of the rear panel).

*This space unintentionally left blank. Oops!**

**Consider drawing a cool dragon.*

Quick Start Guide

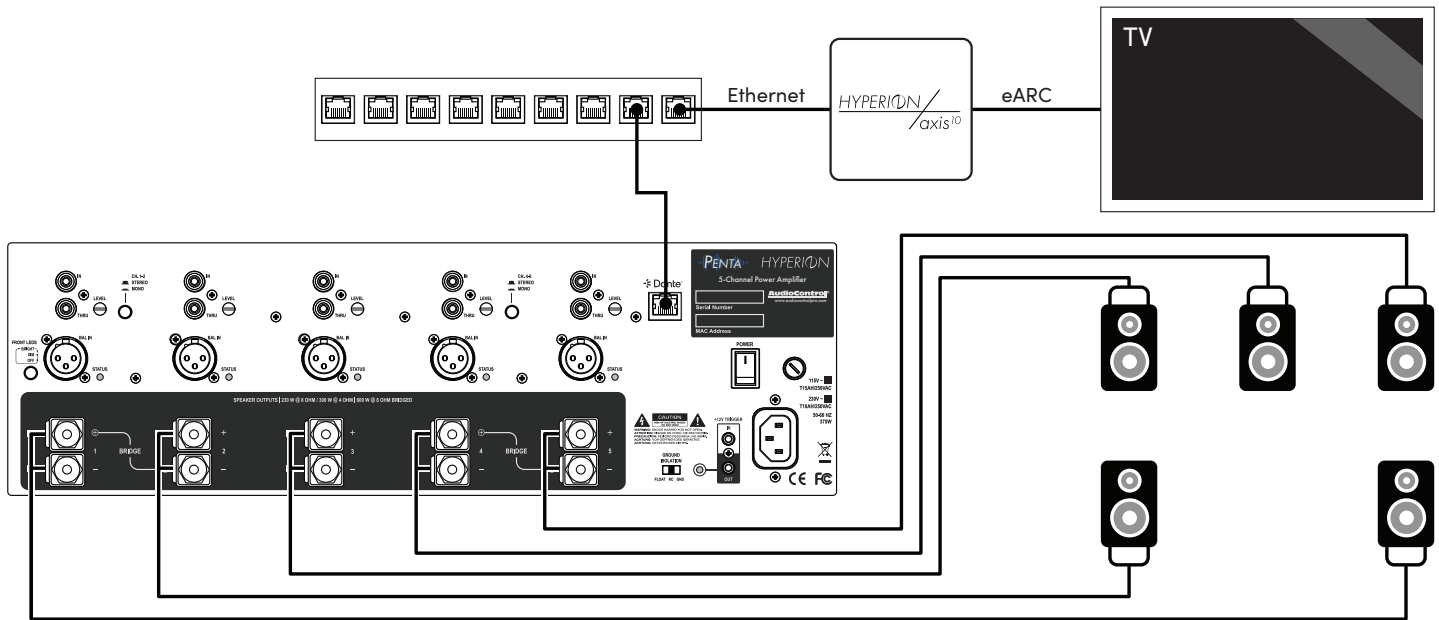

1. Connect the Penta to power.
2. Connect sources to the amplifier, either using the Dante port or the analog inputs.
If using the Dante port, route audio from the source to the Penta in Dante Controller.
3. Connect the Penta's output channels to speakers.
4. If a crossover is needed, adjust the crossover settings now.
5. Power the Penta on by flipping the main AC Power Switch.
6. Wake the Penta either by pressing the Power button on the front panel, or using an external trigger.
7. Play content from the source and make sure all outputs are functioning properly.
8. Have a dance party.

Speaker Wiring

Note the polarity markings for each pair of outputs, and match those to the positive and negative terminals on your speakers.

Stereo Speaker Connection

The minimum impedance on a single channel (when not bridged) is 4 Ohms.

Connect your speaker wire of choice from the binding post to your speaker as marked.

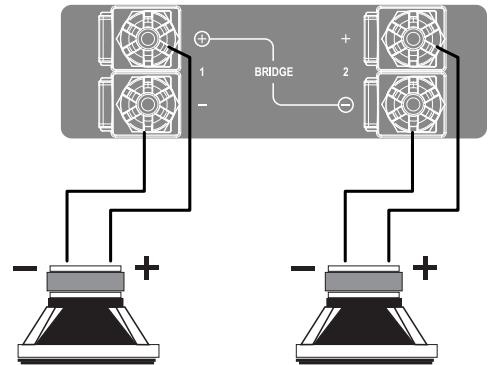

Bridged Mono Speaker Connection

The minimum impedance for a bridged output is 8 Ohms. Any lower than 8 Ohms, and the amp will go into protect.

Note the polarity markings of the bridged pair connections. Use the positive terminal from the first channel in the group, and the negative terminal from the second channel in the group.

Bridging combines the power of both channels to drive a single, more powerful speaker.

When in bridged mode, make sure the Stereo/ Mono button is set to Mono, lest the audio gremlins prevent audio from passing to the speaker.

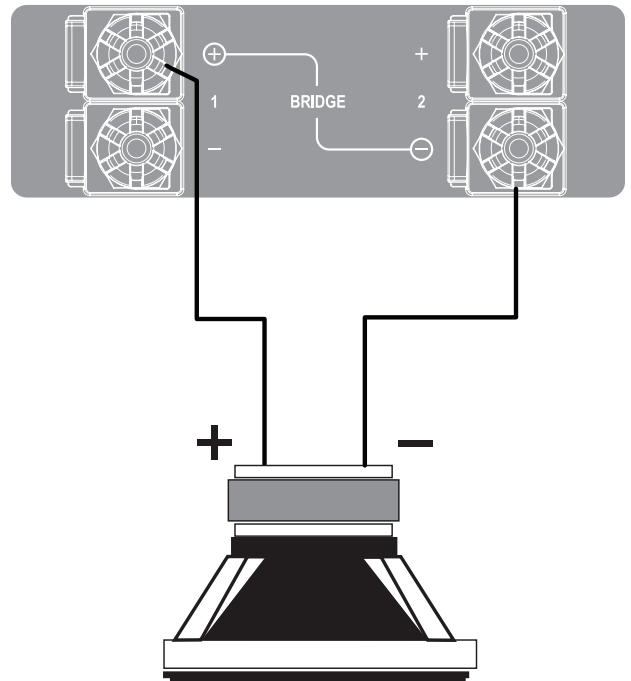

Channels 1 & 2 can be bridged together, and Channels 4 & 5 can be bridged together. Channel 3 is proudly independent.

Installation

Placement

The Penta is a cool running amplifier, with the Class H power supply dynamically allocating power and keeping the amp cool for its lifetime. Precautions should be made so that it does have a bit of breathing room—it’s a powerful amplifier after all.

Air vents on the amplifier should not be blocked, and have at least 1/4” of airspace. Heat sensitive components such as cable boxes and game consoles should not be placed directly on top of the Penta.

The Penta comes preinstalled with 4 feet so it can stand clear in any media center, or hide on a closet shelf.

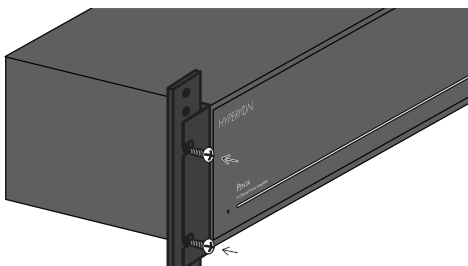
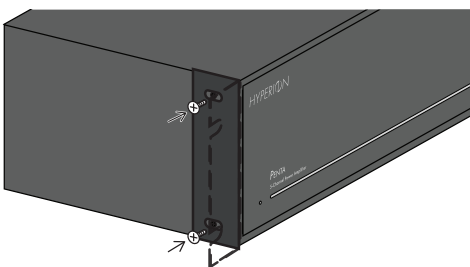
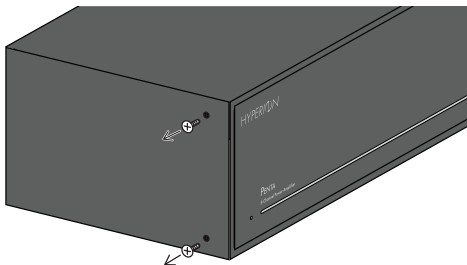
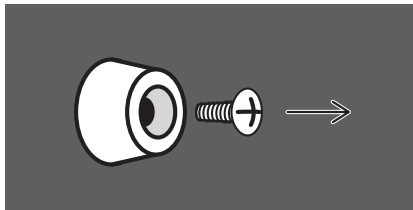

Rack Mounting

To install the Penta into an amp rack, remove the 4 feet by removing the screw holding each foot in place with a Phillips-head screwdriver.

Unscrew the 2 side screws on the each side of the face plate and set them aside. Place the rack ear over the screw holes with the mounting side flush with the front panel, then use the screws set aside to hold the rack ear in place. Repeat on the other side.

Slot the amplifier into the rack, and raise it to the desired level. Use 4 rack screws to affix the amplifier to the rack.

Do not stack more than 2 models together. Any more than that, and a rack space above and below the 2 units is required for adequate ventilation.

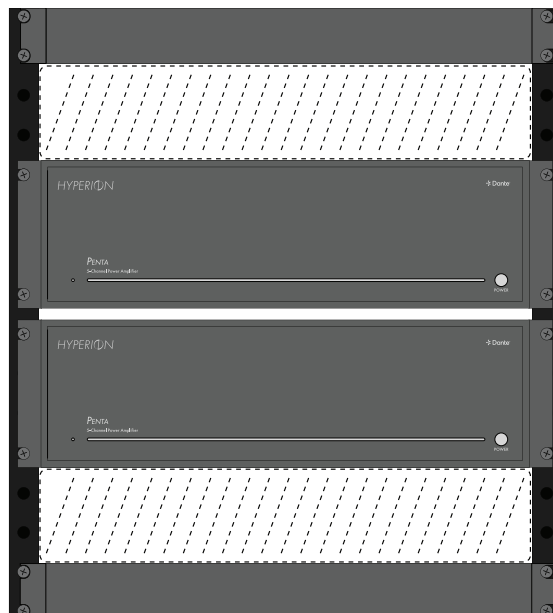

Speaker Configurations

As a 5 channel amp, the Penta gives you unparalleled running power that can handle any speaker, and multiple configurations.

5 Channels

These 5 channels offer 230W at 8 Ohms and 300W at 4 Ohms. This will render your content in fantastic detail. Connect your Left, Center, Right, and Surrounds, and enjoy!

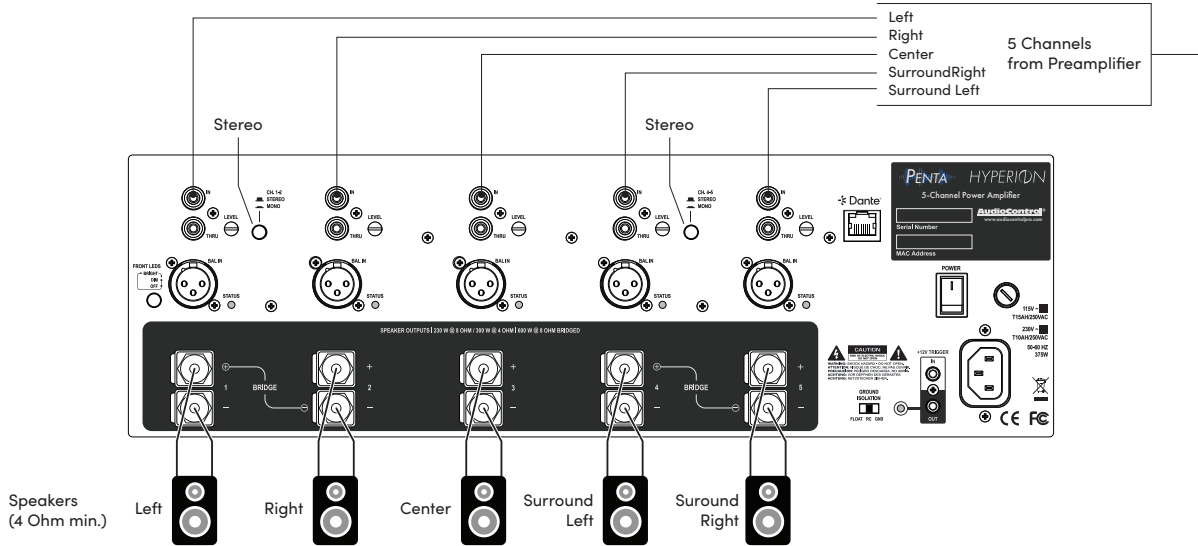

3.1 Channels

Bridge an 8 ohm passive subwoofer to one pair of outputs to get over 600 watts driving it! Left, Center, and Right channels can be driven by the remaining channels. Everything you need in one convenient package!

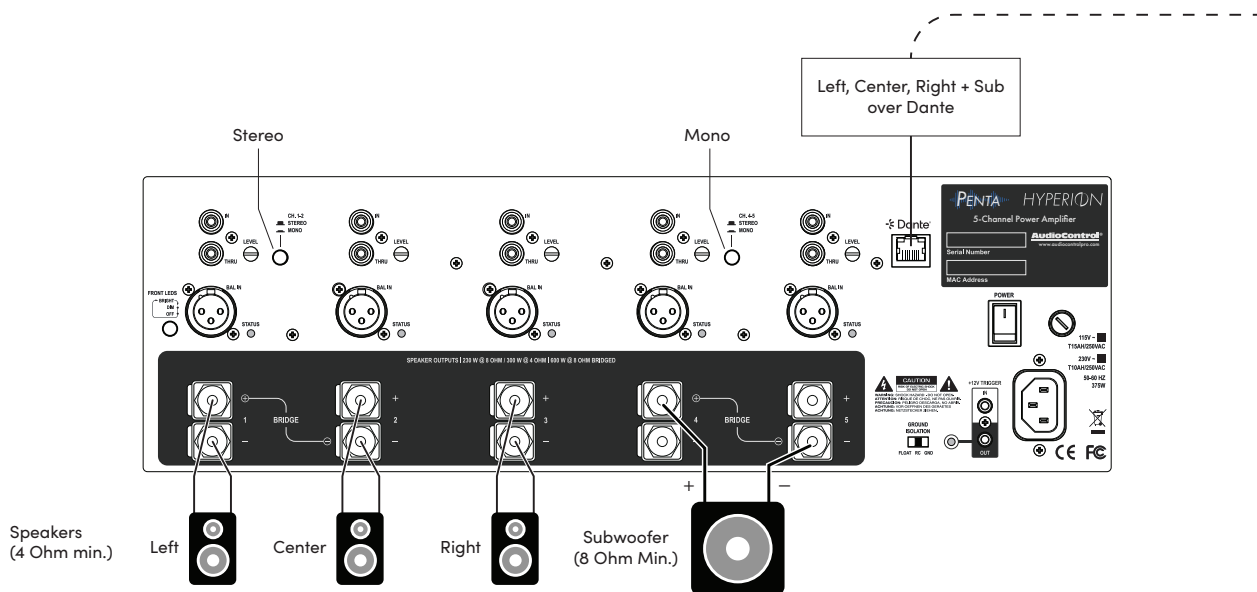

3 Channels with Bridged Mono

If you have two 8 ohm speakers that can handle the amazing power of the Hyperion Penta's 600 watts, hook 'em up in bridged mono! Run the left Channel 1 input, and the right output to the Channel 4 input (no need to connect anything to inputs 2 or 5), and send the center channel to Channel 3.

A solo, non-bridged outputs channel can handle a speaker with a minimum of 4 ohms, speakers on bridged outputs cannot go lower than 8 ohms!

Press the mono button for each channel pair and adjust the gain levels so they are the same. Use the detents for quick set up—you'll have more than enough gain to blow out your windows if that's your thing.

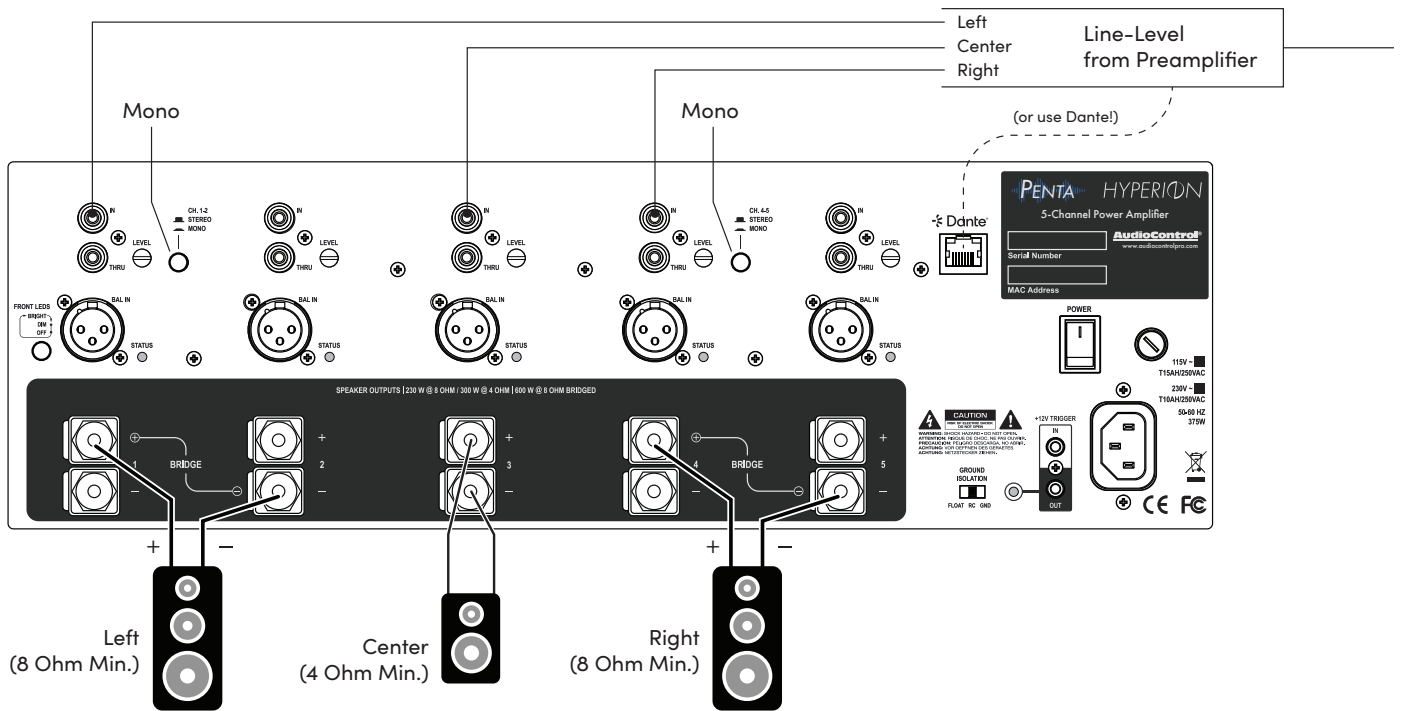

+12V Trigger In/Out

It's important to practice proper trigger safety when handling a Hyperion amplifier! Thankfully, we've made it quite simple to manage.

Wiring

Wiring a TS cable yourself? Make sure the tip is connected to the positive lead, and the sleeve is connected to ground.

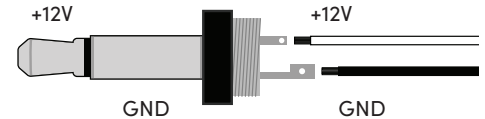

Input

When a trigger wire is connected to the input of the amplifier, the amp is connected to power and the main switch is ON. When there is no voltage on the trigger wire, the amp will remain in standby. As soon as +12V is present on the trigger, the amp will turn on, and acoustic enjoyment can begin.

Typically, the power trigger will come from a pre-processor or from another amp's trigger output.

Output

When the amplifier is turned on by an external +12V trigger, the output will have +12V present, ready to trigger on another device in your system.

For example, the Pre-Amp triggers the Penta on, a TS wire is run from the trigger out to the trigger in of a Tetra, and out from that to the in of a Hepta, turning all 3 devices on!

The trigger output can go from one Hype amp's out to another's in over and over again, ad infinitum. You can y-cord trigger connections from the output to multiple inputs, but if you need more than 15 milliamps current, use a relay to prevent overloading the Penta (it only takes 1mA to turn on).

Status LED

The Trigger Status LED will illuminate blue whenever +12V is detected on the trigger input.

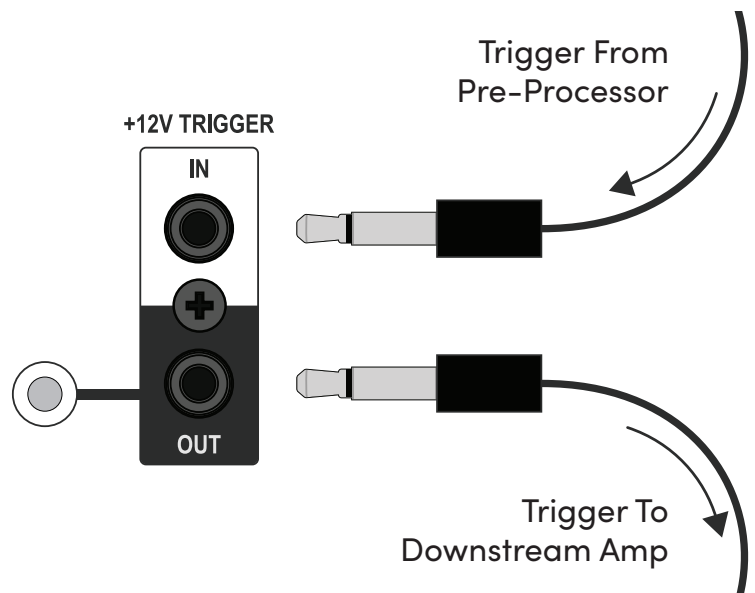

Using Dante Controller

To transmit audio streams from the Dante Enabled devices to the Penta, it's recommended to download the Dante Controller software from Audinate.

<https://www.getdante.com/support/software-downloads/#dante-controller>

Using the Software

Once Dante Controller is installed and opened, it will display a grid of all the transmitting and receiving Dante devices on the network.

The Penta has 5 Receiving channels.

Route audio from a transmitter (or transmitters) to the receiving channels of the Penta, then play audio from the source to make sure audio is being received properly.

The screenshot shows the Dante Controller interface with a routing grid. On the left, there are filter fields for transmitters and receivers. The transmitter list includes 'AXIS10-020ae7'. The receiver list includes 'HEPTA-020aeb' and 'PENTA-020aef'. The PENTA-020aef receiver is expanded to show five channels: CH-1, CH-2, CH-3, CH-4, and CH-5. The routing grid shows connections from the transmitter to the receiver channels: CH-1 is connected to FL, CH-2 to FR, CH-3 to FC, CH-4 to Sub/LFE, and CH-5 to SL. A bracket on the right side of the grid labels the transmitter columns as 'Audio Channels from Dante Transmitter', and a bracket on the left side labels the receiver rows as 'Penta Receive Channels'.

Dante Device Settings

Double clicking the device name in Dante Controller gives you access to additional information and device-specific settings. For example, you can turn on AES67 for the Penta if you plan to use it.

Penta Settings

The Mono/Stereo button and crossover settings will apply to any incoming signal before it goes to the output, so these will work for analog and Dante audio sources.

The RCA Thru output only works for analog audio sources.

For more information, check out the video tutorials on www.getdante.com, or check out our knowledge base at support.audiocontrolpro.com.

Troubleshooting

No Sound

- Verify the front panel LED is blue.
- Check that the Penta is not in standby mode (LED red).
- Check the input wiring from your sources to the Penta inputs.
- If using audio over IP, check that audio signals are routed correctly in Dante Controller.
- Verify the source unit is operating correctly and playing, not paused.
- Check the speaker connections on the rear panel are secure.
- If the unit does not power up at all, unplug the power cord and check the AC Power Fuse on the rear panel.
- Check that the crossover settings are matched to your speakers.

Speaker Buzzing or Crackling at High Volume

- Reduce preamp/equalizer low-frequency boost.
- Turn off your “Sounds of the Pacific Northwest” chainsaw and bacon-frying CD.
- Check that crossover settings are matched to your speakers.

Amplifier in Protect

- Remove power from amp and disconnect all inputs and outputs for 1 minute. Power amp back on with nothing connected.
- Confirm there are no shorts with speakers or speaker wires.
- Check AC Fuse.
- Disconnect from power for 10 minutes.

Output Channel has Red Status LED

- Check speaker wiring.
- Power cycle amplifier.
- Confirm the audio from an analog source is line-level.
- Reduce gain.

Mindfulness

- Take a deep breath, hold it, and chant the specifications page.
- Breathe out slowly while contemplating the joy of Penta ownership.
- Isn't it nice to know that the Penta is so efficient that electrons can be free from the mundane life of room heating, and have more free time and energy to push the loudspeakers around and reproduce your wonderful music.
- Breathe in and out again as normal, assume the “Salute to the Electron” Position while reading the rest of this manual.

Support

If your Penta amplifier needs support, the fine folks on our tech team are happy to help by e-mail or phone call.

We will verify if there is anything wrong in the system that you can correct, or if it needs to be sent in for service.

Please do not return units to us without first obtaining an RMA number from our masterful customer support team.

Phone: 877-886-5112

E-mail: info@avproglobal.com

Knowledge Base: <https://support.avproglobal.com/portal/en/home>

Submit a Ticket: www.avproglobal.com/pages/contact-us

Warranty

In just the same way as being covered in honey and thrown into a dark pit full of hungry woodchucks, people are scared of warranties. Lots of fine print. Months of waiting around. Well, fear no more. This warranty is designed to make you rave about AudioControl. It's a warranty that looks out for you and your client, plus helps you resist the temptation to have your friend Sparky, who's "good with electronics," try to repair your AudioControl product. So go ahead, grab a cup of tea, and carefully read through this warranty.

Our warranty has conditional conditions! "Conditional" doesn't mean anything ominous. The Federal Trade Commission tells all manufacturers to use the term to indicate that certain conditions have to be met before they'll honor the warranty. If you meet all of these conditions, AudioControl will, at its discretion, perform warranty service on any AudioControl products that exhibit defects in materials and/or workmanship during the warranty on your product for five (5) years from the date you bought it, and we will fix or replace it, at our option, during that time.

Here are the conditional conditions:

1. You need to hold on to your sales receipt! All warranty service requires original sales receipt documentation.
The warranty only applies to the original purchaser from an authorized AudioControl dealer. Note: Products purchased from unauthorized dealers are not covered under warranty.
2. If an authorized AudioControl dealer installs your AudioControl product, the warranty is five years, otherwise the warranty is limited to one year.
3. Our warranty covers AudioControl products that have been installed according to the instructions in the installation manual.
4. You cannot let anybody who isn't: (A) the AudioControl factory; or (B) somebody authorized in writing by AudioControl service your AudioControl product. If anyone other than (A), or (B) messes with your AudioControl product, the warranty is void.
5. The warranty is void if the serial number is altered, defaced or removed, or if your product has been used improperly. Now that may sound like a big loophole, but here is what we mean by this: Unwarranted abuse is: (A) physical damage (don't use your product to level your dining room table); (B) improper connections (120 volts into the RCA jacks can fry the poor thing); (C) sadistic things! This is the best product we know how to build, but for example if you mount it to the front bumper of your car, drop it over the Niagara Falls or use it for Clay Pigeon shooting practice, something will go wrong.

Assuming you conform to 1 through 5, and it really isn't all that hard to do, we will have you send your product to us for warranty service.

Legalese Section

This is the only warranty issued by AudioControl. This warranty gives you specific legal rights, and you may also have rights that vary from state to state. Promises of how well your AudioControl product will work are not implied by this warranty. Other than what we've said we'll do in this warranty, we have no obligation, express or implied. We make no warranty of merchantability or fitness for any particular purpose. Also neither we nor anyone else who has been involved in the development or manufacture of the unit will have any liability of any incidental, consequential, special or punitive damages, including but not limited to any lost profits or damage to other parts of your system by hooking up to the unit (whether the claim is one for breach of warranty, negligence of other tort, or any other kind of claim). Some states do not allow limitations of consequential damages.

Thank you for choosing AudioControl!
Please contact us with any questions, we are
happily at your service!

AudioControl®

an **AV** Pro  company

877-886-5112

info@avproglobal.com